

# PPM INSTALLATION Cont.

## Unit I.D. Number Programming

Each Bus Module must have its own unique unit ID number, 0 through 7. Verify all ID numbers on the system so you don't repeat any.

### To Program Unit ID Number:

1. Arrange the 3-position DIP switch in the configuration you wish to use.

The switch positions are as follows:

1	2	3	UNIT ID
OFF	OFF	OFF	0
OFF	OFF	ON	1
OFF	ON	OFF	2
OFF	ON	ON	3
ON	OFF	OFF	4
ON	OFF	ON	5
ON	ON	OFF	6
ON	ON	ON	7

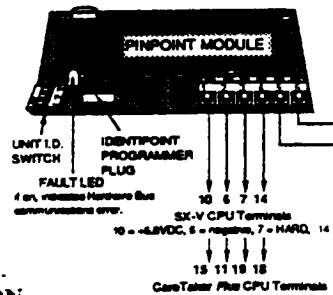

2. Turn the CPU power switch to ON.
3. Turn the CPU program switch to ON
4. Using a Wireless or Hardwire Touchpad, delete Sensor 77 by entering "Bypass 77." The bouncing balls in the display will confirm the bypassing. Leave the CPU program switch ON.
5. Using a Wireless or a Hardwire Touchpad, re-enter sensor number 77 into the CPU memory by entering "status 77." The bouncing balls in the display will confirm the entry.
6. Turn the CPU program switch to OFF.

Note: If "77 Supervisory" appears on the CPU display, verify that all bus devices have different unit ID numbers.

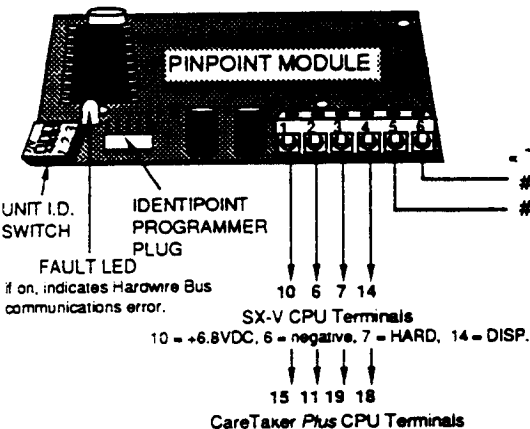

## PPM TAMPER ZONE

### To Install Tamper Zone:

1. Install a 1/4" recessed reed switch in the plastic base and magnet into plastic cover.
2. With CPU power switch OFF, connect tamper switch to a DPA wired into the PA loop.

### To Remove Tamper Zone:

1. Turn the CPU power switch OFF.
2. Remove the tamper DPA from the PA loop if connected.

### To Program Tamper Zone:

1. See DPA PROGRAMMING section. Disable unused zone, cut tooth 10 or 11.
2. Turn CPU Power switch ON, verify tamper switch operation during sensor test by removing module cover.

### To Delete PPM Tamper Zone From CPU:

1. Turn the CPU power switch to ON.
2. Put the CPU program switch to ON.
3. With the CPU in the program mode, press the Bypass key on any touchpad, immediately followed by the tamper zone number.
4. The CPU "bouncing balls" and beep will confirm that the tamper zone (sensor) number has been deleted. The tamper zone number will no longer show on the CPU display.
5. Turn the CPU program switch to OFF.

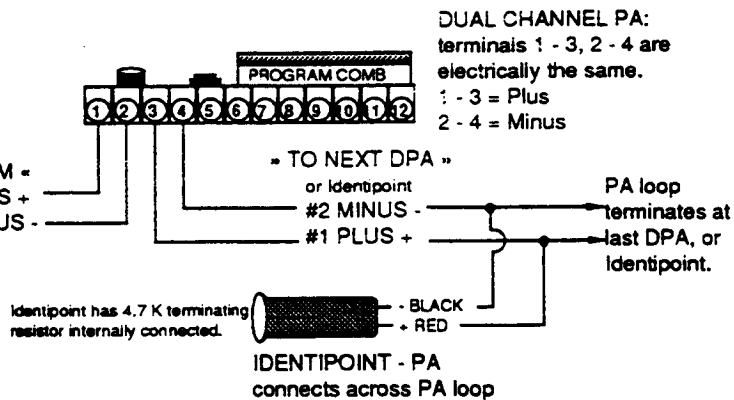

## DUAL CHANNEL POINT ANNUNCIATOR (DPA) ITI part # 60-112

The DPA monitors two separate input devices (magnetic switches, PIRs etc.). Because these input devices are connected to the DPA, they use 4.7K terminating resistors. This resistor can be terminated either internally or externally at the device. The PPM sends out a synchronizing tone burst to all PAs, which starts a scan. Each PA is programmed with a unique identity (sensor) number, which defines the time slot when the PA is to send its response back to the PPM. The response defines the state of the sensor, normal or alarm. No response is defined as a trouble condition. The PPM always expects a response from the PAs, so the system is completely supervised. Each scan takes 3 seconds and the average response time to the CPU is 1.5 seconds.

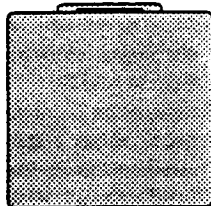

The DPA is programmed by a programming comb. Bending or cutting the comb teeth determines its point (zone - sensor) number, response time and the disabling of any unused points.

### Tooth Descriptions

- 1 - 6 Point zone numbers.
- 7 Ground pin. **DO NOT CUT.**
- 8 Fast response, ODD point (zone) number. If cut, loop response = 7 msec. If not cut, loop response = 250 msec.
- 9 Fast response, EVEN point (zone) number. If cut, loop response = 7 msec. If not cut, loop response = 250 msec.
- 10 Disable the *EVEN* point (zone) number.\*
- 11 Disable the *ODD* point (zone) number.\*

\* If you are using only one of the point channels, you must disable the unused number. If you do not, the unused point (zone) number will self-program itself into the CPU when it is in the program mode.

**DO NOT CUT THE WIDE PIN.** The key pin prevents the comb from being installed backwards. If this pin is cut, the DPA will be programmed improperly.

# DUAL CHANNEL POINT ANNUNCIATOR (DPA) ITI part # 60-112

## DPA Programming

To program the DPA, use the program comb. Remove the programming comb from each of the PAs. Using the planning chart that follows, cut or bend the teeth in the comb to program the PA.

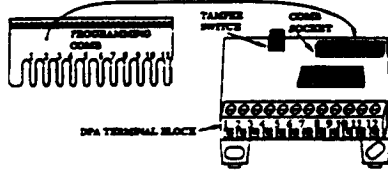

- 1) **Sensor Number:** is the POINT ID (zone) number.
- 2) **Tooth #:** is the tooth number to be cut for a specific sensor number.
- 3) **Disable:** disables EVEN or ODD sensors on each DPA. Example:  
To disable sensor 2, cut tooth 10; to disable sensor 3, cut tooth 11.
- 4) **Fast Response:** Normal loop response time is 250 milliseconds when tooth is not cut. When cut, a 7-millisecond loop response time is enabled. Tooth 8 should be cut for the even number zone, tooth 9 for the odd.

### To Program DPA Zone Numbers into the CPU:

1. Replace all DPA covers, this closes the tamper switch. Make sure the CPU program switch is OFF while you close the covers, so the PPM sees the tamper restorals.
2. Turn the CPU program switch to ON, the zones will self-program into the CPU. If any of the zones do not self-program, activate the switches connected to the DPA.

**Note:** Do not initialize PA zones into the CPU with an RF touchpad. The CPU will consider these zones as radio transmitters and you will get "01 BAD SENSOR number" when it sees the PA zones trip.

### To Delete DPA Zone Number From the CPU:

1. Turn the CPU power switch OFF. Remove the DPA from the PA loop, (or cut either tooth number 10 or 11 to disable just one of the zones).
2. Turn the CPU power switch to ON. Turn the CPU program switch to ON, press the Bypass key immediately followed by the desired sensor numbers on any touchpad (RF or hardwired). The CPU "bouncing balls" and beep will confirm that the zone (sensor) number has been deleted. The zone number will no longer show on the CPU display.
3. Turn the CPU program switch to OFF.

1	2	3	4
Sensor Number	Tooth #	Disable	Fast Response
2 and 3	6	10 or 11	8 or 9
4 and 5	5	10 or 11	8 or 9
6 and 7	5-6	10 or 11	8 or 9
10 and 11	4	10 or 11	8 or 9
12 and 13	4-6	10 or 11	8 or 9
14 and 15	4-5	10 or 11	8 or 9
16 and 17	4-5-6	10 or 11	8 or 9
20 and 21	3	10 or 11	8 or 9
22 and 23	3-6	10 or 11	8 or 9
24 and 25	3-5	10 or 11	8 or 9
26 and 27	3-5-6	10 or 11	8 or 9
30 and 31	3-4	10 or 11	8 or 9
32 and 33	3-4-6	10 or 11	8 or 9
34 and 35	3-4-5	10 or 11	8 or 9
36 and 37	3-4-5-6	10 or 11	8 or 9
4 and 41	2	10 or 11	8 or 9
42 and 43	2-6	10 or 11	8 or 9
44 and 45	2-5	10 or 11	8 or 9
46 and 47	2-5-6	10 or 11	8 or 9
50 and 51	2-4	10 or 11	8 or 9
52 and 53	2-4-6	10 or 11	8 or 9
54 and 55	2-4-5	10 or 11	8 or 9
56 and 57	2-4-5-6	10 or 11	8 or 9
60 and 61	2-3	10 or 11	8 or 9
62 and 63	2-3-6	10 or 11	8 or 9
64 and 65	2-3-5	10 or 11	8 or 9
66 and 67	2-3-5-6	10 or 11	8 or 9
70 and 71	2-3-4	10 or 11	8 or 9
72 and 73	2-3-4-6	10 or 11	8 or 9
74 and 75	2-3-4-5	10 or 11	8 or 9
76 and *77	2-3-4-5-6	10 or 11	8 or 9

### Additional Notes:

- If sensor 76 is programmed, sensor 77 must be disabled. (You must cut tooth 11)
- Never cut tooth 7, this is the ground pin.
- Do Not cut the wide pin, this is the alignment pin.
- After programming the teeth, write the sensor numbers on the programming combs for easy identification.

**Note:** P.A. sensor numbers conform to the standard SX-V group number and letter codes. Regrouping the sensor numbers is done by the CS-4000 in the usual manor.

## DPA INPUT LOOP WIRING DIAGRAM

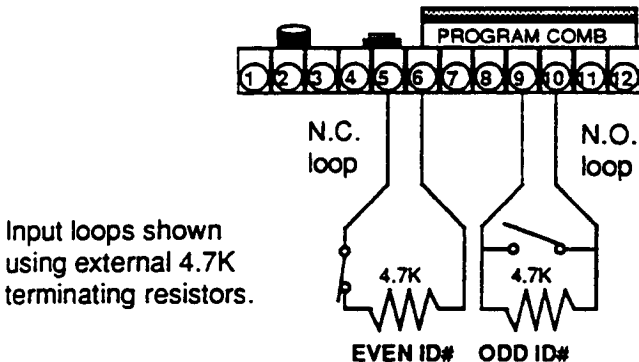

Input loops shown using external 4.7K terminating resistors.

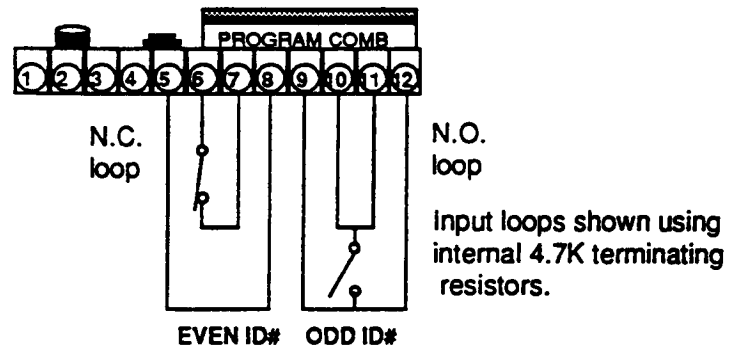

Input loops shown using internal 4.7K terminating resistors.

On any DPA you can wire both input loop's either Normally Open, or Normally Closed. If multiple contacts are used, wire N.O. in parallel, N.C. in series. You cannot power any input devices (PIR, smokes, etc.) from the PA loop. A separate power supply would be needed.

# IDENTIPOINT INSTALLATION

## Identipoint Single Channel PA

ITI part number 60-264 Recessed Mount Switch  
ITI part number 60-265 Surface Mount Switch

The Identipoint PA monitors one door or window only. Remote input devices (PIRs etc.) cannot be wired into it. It has a 4.7K terminating resistor and electronic circuit board contained with the N/C reed switch within its plastic housing. Its unique identity (sensor) number is programmed by the HandHeld Programmer via the Pinpoint Module. It can only be used in a normally closed (open causes alarm) configuration. It responds to the PPM in the same manor as the DPA.

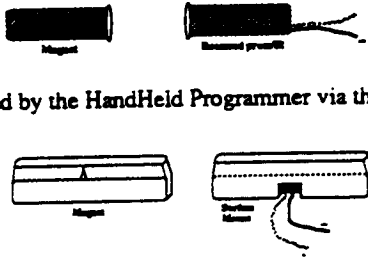

### Identipoint Installation

Identipoints install in the same manor as an ordinary recessed or surface magnetic switch. They are wired parallel into the PA loop using two wires, observing polarity (see diagram).

### Identipoint Programming

Identipoint programming is done by using the SX-V HandHeld Programmer. First, wire the Identipoints to the PinPoint Module as described previously. Before beginning programming, all of the following conditions must be met:

- The Identipoint to be programmed, must be open, and the magnet removed.
- It must be the only PA reporting an open condition.
- It must be assigned an sensor (zone) number not already in use.

1. Turn the CPU programming switch to ON.
2. Plug the programming cord into the PinPoint Module. Observe polarity. Make sure the magnet is removed from the Identipoint you wish to program.
3. Press the "ON" key of the HandHeld Programmer. The display will show "HELLO."
4. Press the HOUSE CODE key on the programmer. The house code digits in the display will flash.
5. Enter the unit ID number (0-7) previously assigned to the PinPoint Module (must be the same for all Identipoints).
6. Press the SENSOR NUMBER key on the programmer. The two sensor digits in the display will flash.
7. Enter the desired point sensor (zone) number for the open Identipoint. (Programming must be done using octal numbering, no 8's and 9's.) This number will display and flash.
8. Press the ENTER key. If programming is successful, the "Done" will be displayed. If "FAIL" is displayed, check the cable connections and press ENTER again.
9. Wait 10 seconds for the system to reinitialize, then press the READ key. The display should show the desired unit number, point zone number, and sensor type. For an SX-V, the zone number will self initialize itself into the CPU, for a CareTaker Plus the zone must be learned.
10. If you wish to program another Identipoint, repeat steps 5 through 10 for as many times as needed.
12. Press the OFF key. "Bye" will be displayed.
13. Disconnect programming cord from the PinPoint Module.
14. Turn the CPU programming switch to OFF.

### To Delete Identipoint Zone (Sensor) Numbers:

1. Turn the CPU power switch to OFF.
2. Remove the wires from the PA loop, which are connected to the Identipoint that is to be deleted. The Identipoint is now out of the PA loop circuit and the PPM can no longer communicate with it. The Identipoint zone number is not stored in the PPM, disconnecting it from the PA loop is all that is necessary to remove it from the PPM.

3. Turn the CPU power switch to ON.
4. Turn the CPU program switch to ON.
5. On any touchpad (RF or hardwired) press the Bypass key immediately followed by the Identipoint zone number to be deleted. The CPU "bouncing balls" and a beep confirms that the zone number was deleted. The zone number will no longer show on the CPU display.
6. Turn the CPU program switch to OFF.

### DPA Programming (For CareTaker Plus)

#### Notes:

- PPM software Rev. E and newer is required for CareTaker Plus.
- The Identipoint must be open (the magnet removed) to program.
- It must be the only PA reporting an open condition.
- It must be assigned an sensor (zone) number not already in use.

1. Replace all DPA covers, this closes the tamper switch. Make sure the CPU program switch is OFF while you close the covers, so the PPM sees the tamper restorals.
2. Enter program mode by turning the Tamper Bypass switch to NORMAL.
3. Press the BYPASS button until the display shows LEARN SENSORS.
4. Press the COMMAND button, the display shows LEARN GROUP.
5. Enter the group number (refer to the installation manual for group number descriptions), and press COMMAND.
6. The display shows LEARN Sn - - (- - represents the next available sensor number). Press the COMMAND if that sensor number is the desired number, or enter the desired sensor number by pressing the correct 2-digit number on the touchpad and then press the COMMAND button.
7. The display shows TRIP Sn - - (- - represents the sensor number chosen in step 6), trip the switch that represents that sensor number.
8. Repeat steps 4 through 7 for the rest of the zones to be programmed.
9. Exit program mode by replacing the cover.

### Identipoint Programming (For CareTaker Plus)

1. Plug the programming cord into the PinPoint Module. Observe polarity. Make sure the magnet is removed from the Identipoint you wish to program.
2. Press the "ON" key of the HandHeld Programmer. The display will show "HELLO."
3. Press the HOUSE CODE key on the programmer. The house code digits in the display will flash.
4. Enter the UNIT I.D. NUMBER (0-7) previously assigned to the PinPoint Module (must be the same for all Identipoints).
5. Press the SENSOR NUMBER key on the programmer. The two sensor digits in the display will flash.
6. Enter the desired POINT SENSOR (ZONE) NUMBER for the open Identipoint. This number will display and flash.
7. Press the ENTER key. If programming is successful, the "Done" will be displayed. If "FAIL" is displayed, check the cable connections and press ENTER again.
8. Wait 10 seconds for the system to reinitialize.
9. If you wish to program another Identipoint, repeat steps 5 through 10 for as many times as needed.
10. Press the OFF key. "Bye" will be displayed.
11. Disconnect programming cord from the PinPoint Module.
12. To program these zones into the CPU, follow steps 4 through 8 of the DPA PROGRAMMING (For CareTaker Plus).

### Testing

To test the DPAs and Identipoints, arm the CPU to level 9 "sensor test" and activate each zone, in turn and monitor the SX-V CPU display. Each point you activate should be displayed on the SX-V, and then disappear from the CPU display. Remember that a full loop scan can take 3 full seconds. If there is any problem, check your wiring and your programming and test again, refer to the SX-V or the CareTaker Plus installation manual Sensor Test Section for more testing information.